

Connection Pipe / DIN 42551 F

Yağ Boşaltma Mekanizması

The Connection pipe is a tool to connect the oil drain valves A DIN 42551 to an external oil-system.
 The connection pipe is manufactured in 2 sizes and can be reduced of Nominal width NW 31 to NW 22 or from NW 40 to NW 31.

Connection Pipe	NW	d13	d14	L1	L2	Z
F22/31 DIN 42 551	22	M 48x1,5	M 33x1,5	145	260	11
F31/40 DIN 42 551	31	M 60x2	M 48x1,5	180	270	17
F31 DIN 42 551	31	M 48x1,5	-----	145	260	17
F40 DIN 42 551	40	M 60x2	-----	180	295	17

Accessory parts:

Reduction M 60x2 to 1 1/2" internal thread.
 Reduction M 48x1,5 to 1" internal thread.

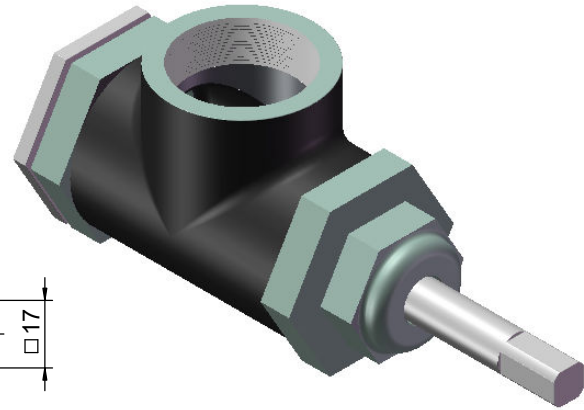
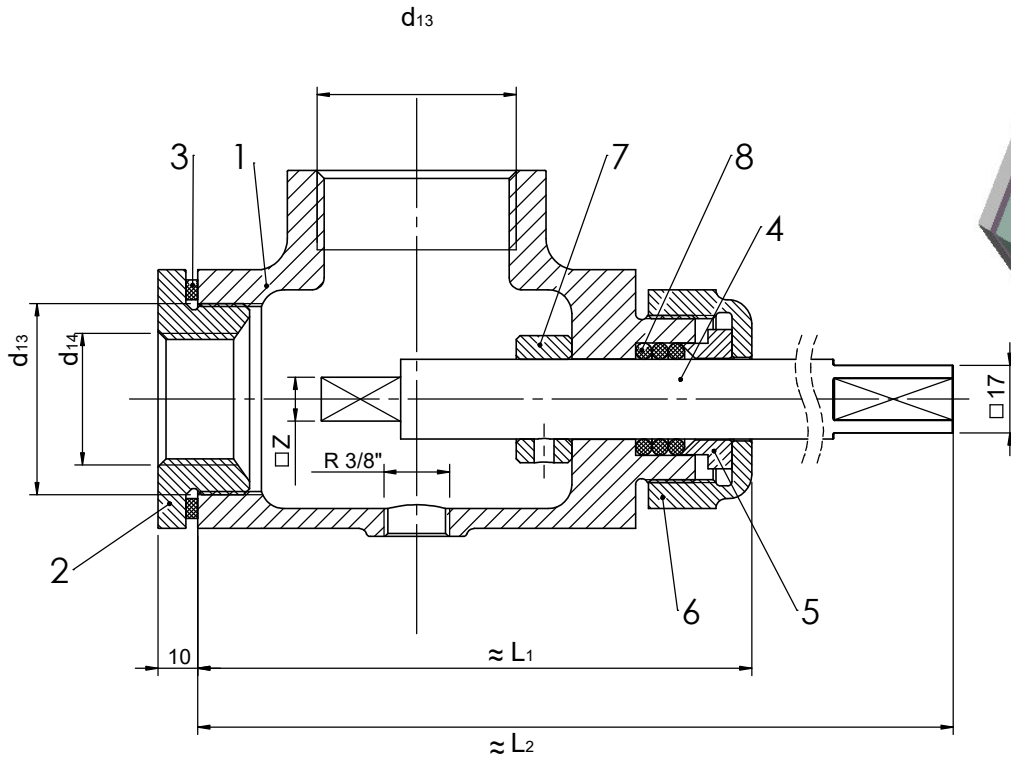

A complete Connection pipe F DIN 42551 consists of:

Item	Q'ty	Connection Pipe	F 22/31 DIN 42551	F 31/40 DIN 42551	F 31 DIN 42551	F 40 DIN 42551	Material
1	1	Housing	G 65 DIN 42551	G 80 DIN 42551	G 65 DIN 42551	G 80 DIN 42551	GG-18
2	1	Reduction	H 22/31 DIN 42551	H31/40 DIN 42551	-----	-----	St 34
3	1	Gasket	D 31 DIN 42551	D 40 DIN 42551	-----	-----	Klingrit,AFM
4	1	Spindle	K1 DIN 42551	K2 DIN 42551	K3 DIN 42551	K3 DIN 42551	St 34
5	1	Packing Box	L DIN 42551				St 34
6	1	Screw Cap	N DIN 42551				GG-20
7	1	Stop Ring	B 20 DIN 705				St 34
8	1	Packing	NBR 70				